

Application and Installation Guide

Physical Property Data

Chemical Resistance Data

Product Bulletin #505-0005



Bailey-Parks
Urethane

Solutions...Not Problems
1-800-238-7638

184 Gilbert Avenue
Memphis, Tennessee 38106
www.baileyparks.com
sales@baileyparks.com

Phone: 901-774-7930
Fax: 901-774-8444

Diamondback® Urethane Products

A Practical Approach to Abrasion Resistance

Where to Use Diamondback®

The following are applications in which Diamondback® has been successfully used. If your particular application is not listed, please contact our Sales Department for technical assistance.

Grain Industry – Areas of the bucket elevator including head section, distributors, transitions, elbows, spouts and chutes, and screw conveyors.

Mining and Related – Spouts and chutes, elbows, bins and hoppers, belt scrapers, noise and vibration dampening, feed boxes, classifier shoes, perforated particle sizing screens, and skirt boards.

Concrete – Lining of central batch mixers and blades.

Foundry Castings – Lining of vibratory trough for deburring of parts. Sandblast and shotblast curtains.

Note: Diamondback® is not recommended for use in areas with a vertical incline of less than 10°, or areas with constant temperatures of 180° F (82° C) or greater.

How to Install Diamondback® Flat Sheet and Pads

Diamondback® sheet is available with expanded metal backing, Slotback™ metal backing, cotton fabric backing and non-reinforced, with no backing.

Generally speaking, the type of backing is a matter of individual preference. In thinner sections, for example

B. In square or rectangular chutes the entire bottom should be lined, as well as 75–80% of the side walls – side walls should be lined first, bottom last.

3/16"–1/2" (4.8mm–12.7mm) thick, many users opt for expanded metal back or Slotback™ metal back because the metal adds rigidity to the urethane, allowing it to lay flatter when installed. The metal backing also allows mechanical forming of the fabricated pieces. Lastly, the metal backing greatly reduces the rate of thermal expansion and contraction as the operating temperature fluctuates from hot to cold and vice versa. As the thickness increases, the need for metal

backing, in many cases, diminishes. Slotback™ metal is the recommended backing for use with ceramic chip Diamondback® because of the option of attaching with self drilling screws (further explained in "Fastening Diamondback® Sections").

The fabric back and non-reinforced Diamondback® can be hand formed to conform to shaped metal substrates, while the expand metal back and Slotback™ metal back requires industrial metal rolling equipment for round or shapes with radii, and press brake to form angles.

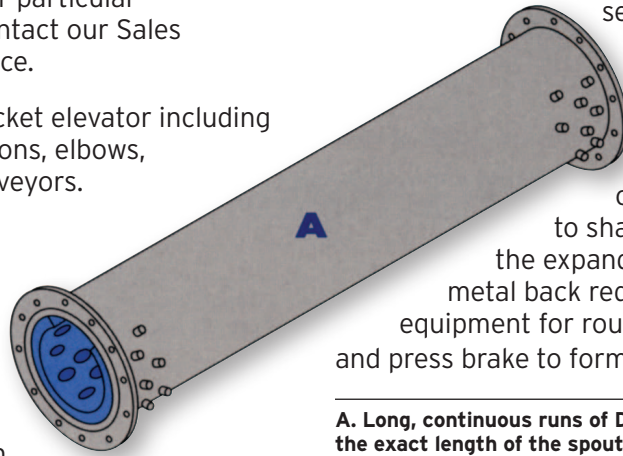

A. Long, continuous runs of Diamondback® can be manufactured to the exact length of the spout you are lining, in one piece – typical installation involves bolting only the top & bottom (as shown here) regardless of spout length.

When lining spouts or chutes with Diamondback® liner it is necessary to cover at least the maximum amount of area effected by abrasion. Generally speaking round spout is lined to cover 80 percent of its inside circumference. (Diagram A) In square or rectangular chutes the entire bottom should be lined as well as 75 to 80 percent of the side walls. (Diagram B)

Cutting Diamondback®

Expanded metal backed and Slotback™ metal backed Diamondback® are most effectively cut by means of a metal cutting shear, either the electric or hydraulic type, rated minimum, for 1/4" (6.4 mm) mild steel plate. Pressures and speeds should be the same as the recommendations for steel plate.

Diamondback® should be sheared with the metal side up. Metal backed Diamondback® can also be cut using a table top band saw. A standard coarse tooth (4 to 5 teeth per 1" [2.5 cm]) blade, run at 1500–2000 RPM is recommended. Do not use a circular saw as friction produced by cutting will cause gumming of the blade, possibly ruining your saw.

In addition to the cutting methods mentioned above, fabric backed and non-reinforced Diamondback® can also be cut with a box board cutter or a rotary slitter with a lubricant feed to cool the blade.

Ceramic chip impregnated Diamondback®, because of the hardness of ceramic, is extremely difficult to saw,

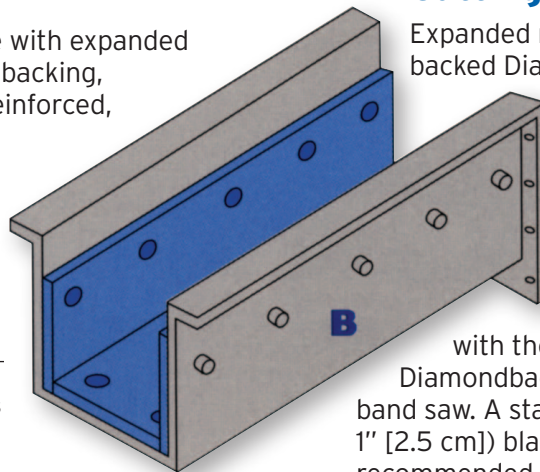

requiring special diamond tipped blades. Even with these blades it is a slow and tedious process.

The best cutting method to date is with a hydraulic shear, rated for 3/8" (9.5 mm) mild steel plate or a scissor type Beverly sheer. Using an electric shear is not recommended as many have a faster cutting stroke and are more likely to hang up, possibly damaging the blade.

Drilling Diamondback®

Diamondback® can be easily drilled with either two or three flute metal drilling bits, either high speed or carbon. Frequent lubrication with kerosene or cutting oil is recommended.

Drilling through ceramic chip impregnated Diamondback® is possible by using a carbide tipped bit, but counter-sinking is virtually impossible.

Fastening Diamondback®

Diamondback®, with all types of backing, is most commonly fastened by means of bolting. Flat head elevator bolts or Bailey-Parks Wedgie Bolts® are recommended. Spacing of the bolts is normally determined by the thickness of the sheet, the type backing and design of the substrate to which it is fastened. As a general rule of thumb, spacing is on 1-1/2" to 2" (3.8 cm–5 cm) centers from the edge of the sheet, with 6"–18" (5 cm–45 cm) center to center spacing throughout sheet. Again, the center to center spacing is determined by the thickness, and also the type backing. 1/4" (6.4 mm) thick expanded metal back can be fastened on 8" (20 cm) centers in a flat section, 1/2" (12.7 mm) thick on 10" (25 cm) centers. The same thickness with no backing should be installed, respectively, on 6" (15 cm) and 8" (20 cm) centers. In sections with radii, more bolts are normally needed.

Alternatives to this type fastening are gluing, with fabric back, and self-drilling metal screws with Slotback™ metal back.

When gluing fabric backed Diamondback®, you must completely clean and degrease the surface to which you are bonding. Normally this requires sandblasting, then cleaning with an industrial solvent such as methyl ethyl ketone or acetone. Most good high quality contact cements will do a good job, provided instructions are properly followed. Always refer to the solvent and/or cement manufacturer's MSDS before using.

Slotback™ metal back Diamondback® can be fastened to metal substrates by using self drilling metal screws. To do this a pilot hole must be drilled through the metal substrates and the Diamondback®. The self drilling metal screw is then started through the back of the metal substrate, and up through the back of the Diamondback® sheet. With this method

the Diamondback® sheet is pulled down from the bottom, rather than pushed down from the top, as with a bolt. Center to center spacing is normally 1"–2" (2.5 cm–5 cm) closer than with bolts. This is an especially effective means of installing ceramic chip Diamondback® with Slotback™ metal backing.

A list of chemicals with which Diamondback has varying degrees of compatibility is included on the last page of this bulletin.

For information not covered in this bulletin, please contact our sales office.

Safety Precaution: *prior to fabrication please refer to MSD sheet! Proper safety procedures should be followed whenever cutting, drilling or fabricating Diamondback® in any manner. This includes wearing safety glasses and possibly a supplied-air respirator if cutting or grinding in any manner that produces fumes. Refer to Bailey-Parks Urethane Material Safety Data Sheet for specific precautions if cutting with a hot wire, hot knife, saw or grinder, or any other means that might produce fumes.*

Diamondback® Urethane Liners Physical Properties		
		ASTM#
Shore A Hardness	85	D2240
100% Modulus, PSI (kPa)	763 (5261)	D412
300% Modulus, PSI (kPa)	1670 (11,514)	D412
Tensile, PSI (kPa)	5500 (37,921)	D412
Elongation, %	551	D412
Tear Strength, Die C, pli (kN/M)	550 (97)	D624
Tear, PLI (kN/M)	110 (19.4)	D470
Bashore Rebound, %	35	D2632
Specific Gravity	1.20	D792
Bell Brittle Point, °F (°C)	-58 (-50)	D2137
Complies with FDA criteria regulating dry bulk food contact		

If you have urethane requirements calling for more specialized compounds (i.e., ultra high or low rebound, super low compression set, USDA approved urethanes), please call us.

The recommendations for the use of our products are based on tests that we believe to be reliable. We do not, however, guarantee the results of others under different conditions. Nothing in our brochures or literature is intended as a recommendation to use our products so as to infringe on any patent. All products discussed herein are sold without warranty, express or implied, as to the results the user may obtain with them and on the express understanding that purchasers will conduct their own tests to determine the suitability of such products for their particular purposes.

Chemical, Oil and Solvent Resistance of Diamondback®

1 – Excellent, 2 – Good, 3 – Fair, 4 – Poor

Chemical	Result	Chemical	Result	Chemical	Result	Chemical	Result
Acetaldehyde	4	Calcium Sulfate	2	Hydrobromic Acid	2	Propane	2
Acetic Acid	4-3	Carbon Dioxide	1	Hydrocarbon Oil	2	Propyl Alcohol	3
Acetic Anhydride	4	Carbon Disulfide	2-3	Hydrochloric Acid, 20%	2-3	Propylene Glycol	2
Acetone	4	Carbon Monoxide	1	Hydrofluoric Acid	3	Pydraul Oil	4
Acetyl Bromide	4	Carbon Tetrachloride	4	Hydrogen	2	SAE #10 Oil	
Acetyl Chloride	4	Castor Oil	2	Hydrogen Peroxide	2	Seawater	2
Acetylene	3	Chlorine	2-3	Hydrogen Sulfide	4	Silicic Acid	2
Adipic Acid	2	Chloroacetic Acid	4	Hydroiodic Acid	2	Silver Nitrate	2
Aluminum Chloride	2	Chloroform	4	Iodine Solution	2	Skydrol Oil (500)	3
Aluminum Sulphate	2	Chromic Acid	4	Isooctane	2	Soap	2-3
Aluminum Sulfide	2	Chromium Potassium Sulfate	2	Isopropyl Alcohol (Isopropanol)	3	Sodium Acetate	2
Ammonia	2-3	Citric Acid	2	Isopropyl Ether	2-3	Sodium Bicarbonate	2
Ammonium Acetate	3-4	Cottonseed Oil	2	JP-4 Oil	3	Sodium Bisulfate	2
Ammonium Carbonate	2	Cresol (meta)	4	JP-5 & 6	4	Sodium Borate	2
Ammonium Hydroxide	2	Cupric Chloride	2	Kerosene	2-3	Sodium Carbonate	2
Ammonium Nitrate	2-3	Cupric Nitrate	2	Lactic Acid	2	Sodium Chlorate	2
Ammonium Persulfate	2	Cupric Sulphate	2	Lead Acetate	2	Sodium Chloride	2
Ammonium Sulfate	2	Cyclohexanone	4	Linseed Oil	2-3	Sodium Cyanide	2
Ammonium Sulfide	2	Cyclohexane	2	Lubricating Oil	2-3	Sodium Dichromate	2
Ammonium Thiocyanide	2	Dibutyl Phthalate	4	Magnesium Hydroxide	1-2	Sodium Ferrocyanide	2
Amyl Acetate	4	Dibutyl Ether		Magnesium Salts	2	Sodium Fluoride	2-3
Amyl Alcohol	3-4	Dichlorobenzene (Ortho)	3	Malaic Acid	4	Sodium Hydrosulfite	2
Amyl Chloride	3	Dodecyl Mercaptan	2	Mercury	2	Sodium Hydroxide, 45%	2
Aniline	4	Diester Oil	2	Methyl Alcohol (methanol)	3	Sodium Nitrate	2
Aniline Hydrochloride	4	Dimethyl Acetamide	4	Methyl Ethyl Ketone	4	Sodium Silicate	2
Animal Fats & Oils	2-3	Dimethyl Formamide	4	Methylene Chloride	4	Sodium Sulfate	2
Antimony Salts	2	DTE Oil (heavy, medium)	2-3	MIL-D-5606 Oil	3-4	Sodium Sulfide	2
Aqua Regia	4	Ether	2-3	MIL-L-7808	2-3	Sodium Hypochlorite 5%	4
Arsenic Salts	2	Ethyl Acetate	4	Mineral Oil	1	Sperry Oil	2-3
ASTM Oil #1	1	Ethyl Alcohol (Ethanol)	2-3	Mobil Arctic Oil	2	Steam	4
ASTM Oil #2	1	Ethyl Bromide	3-4	Naphthalene	2-3	Stoddard Solvent	2
ASTM Oil #3	1	Ethyl Chloride	3-4	Natural Gas	2	Styrene	2
ASTM Reference Fuel A	1-2	Ethylene Glycol	2-3	Nickel Salts	3-4	Sulfur Dioxide	2-3
ASTM Reference Fuel B	2	Esso #90 Lub. Oil	2	Nitric Acid	4	Sulfuric Acid, 10 50%	4
Atlantic Oil	1-2	Ferric Chloride	2	Nitrobenzene	4	Tannic Acid, 10%	2
Barium Carbonate	2	Ferric Nitrate	2	Nitrogen	1	Tartaric Acid	2-3
Barium Hydroxide	2	Ferrous Chloride	2	Oleic Acid	2	Tin Salts	2
Benzaldehyde	4	Ferrous Sulfate	2	Oxalic Acid (5%)	1-2	Titanium Salts	2
Benzene	4	Formaldehyde	2	Oxygen	1	Toluene	4
Benzene (Gasoline) (Aromatic)	3	Formic Acid	4	Ozone	1	Transformer Oil	3
Benzoic Acid	3-4	Freon. 12 or 113	2	Palmitic Acid	2	Trichloroacetic Acid	4
Boric acid	2	Fuel Oil	2	Paints	2	Trichloroethylene	4
Bromine	2-3	Gasoline	2-3	Perchloric Acid	4	Tricresyl Phosphate	4
Bunker Oil	2	Glycerine (Glycerol)	2	Perchloroethylene	4	Triethanol Amine	2
Butane	2-3	Glycolic Acid	2-3	Petroleum	2	Trisodium Phosphate	2
Butyl Acetate	4	Greases	2	Phenol (carbolic acid)	4	Turpentine	2
Butyl Alcohol	3	Heptane	2	Phosphoric Acid (dil.)	3	Urea	2
Calcium Carbonate	2	Hexane	2	Phosphoric Acid (conc.)	4	Varnish	2-3
Calcium Chloride	2	Hydrazine	4	Potassium Cyanide	2	Vegetable	2
Calcium Hydroxide	2			Potassium Salts	2	Water	2
Calcium Nitrate	2						



Bailey-Parks Urethane

Solutions...Not Problems

1-800-238-7638

